

Property of
Sensata Technologies

ZONE	REV.	REVISION DESCRIPTION	ECN NO.	DATE
C2	D	ADDED -8; GML	ECN0035248	24-APR-2007

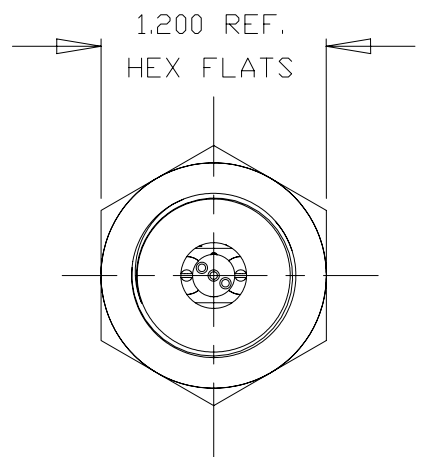

OPERATING TEMPERATURE							
PART NO.	OPEN	CLOSE	DIM "A"	DIM "B"	DOT COLOR	CABLE (OR EQUIV)	ELECTRICAL SCHEMATIC
28509-1	370F +/- 12°F 188C / -6.7°C	330F +/- 12°F 166C / -6.7°C	1.97 REF	4.2 REF	RED-RED	BELDEN 833337E	WIRING SCHEMATIC #1
28509-2	390F +/- 12°F 199C / -6.7°C	350F +/- 12°F 177C / -6.7°C	1.97 REF	4.2 REF	BLUE-BLUE	BELDEN 833337E	WIRING SCHEMATIC #1
28509-3	180F +/- 8°F 82C / -4.4°C	160F +/- 8°F 71C / -4.4°C	1.97 REF	4.2 REF	RED	BELDEN 85231	WIRING SCHEMATIC #2
28509-4	235F +/- 8°F 113C / -4.4°C	205F +/- 8°F 96C / -4.4°C	1.97 REF	4.2 REF	BLUE	BELDEN 85231	WIRING SCHEMATIC #2
28509-5	260F +/- 8°F 127C / -4.4°C	230F +/- 8°F 110C / -4.4°C	1.97 REF	4.2 REF	GREEN	BELDEN 85231	WIRING SCHEMATIC #2
28509-6	260F +/- 8°F 127C / -4.4°C	230F +/- 8°F 110C / -4.4°C	3.97 REF	6.2 REF	BLACK	BELDEN 85231	WIRING SCHEMATIC #2
28509-7	320F +/- 8°F 160C / -4.4°C	280F +/- 8°F 138C / -4.4°C	1.97 REF	4.2 REF	WHITE	BELDEN 85231	WIRING SCHEMATIC #2
28509-8	260F +/- 8°F 127C / -4.4°C	230F +/- 8°F 110C / -4.4°C	2.97 REF	5.2 REF	YELLOW-YELLOW	BELDEN 85231	WIRING SCHEMATIC #2

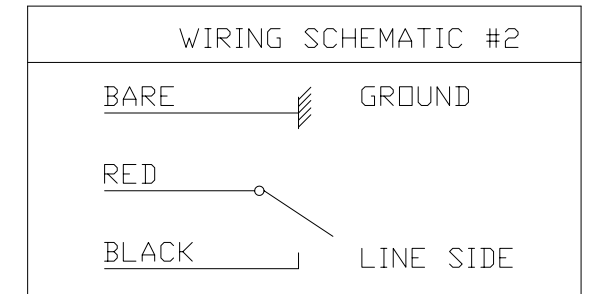
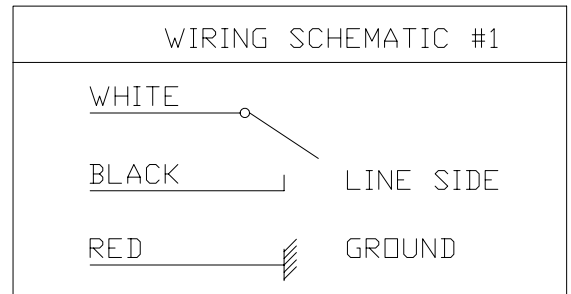
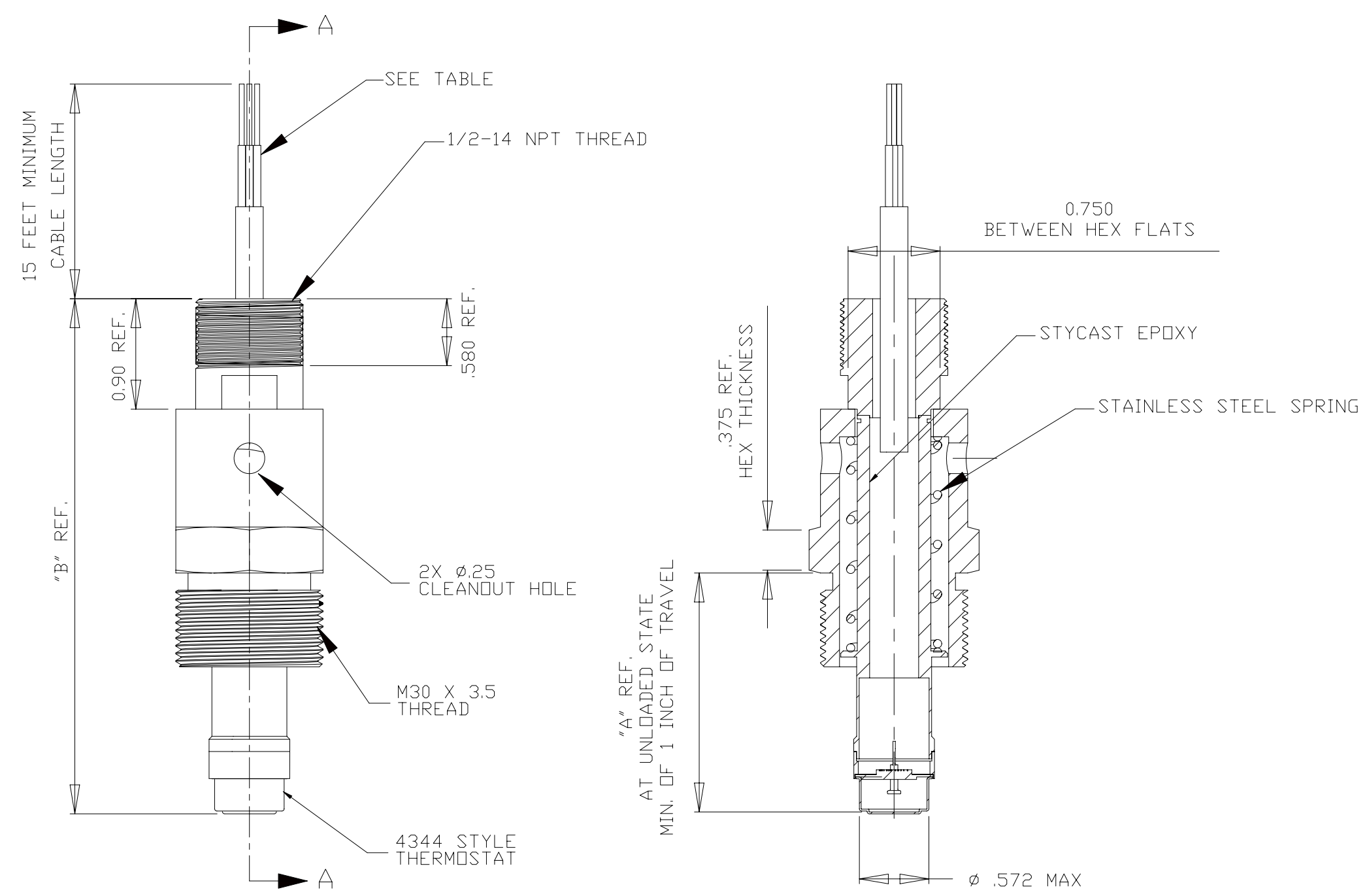

- NOTES:
- BASIC THERMISTAT: 4344 SERIES
 - MATERIAL: 300 SERIES STAINLESS STEEL
 - HOUSING IS GROUNDED TO THE GROUND LEAD OF THE CABLE.
 - TUBE WILL COMPRESS INTO BODY A MINIMUM OF 1 INCH.
 - ELECTROETCH SENSATA TECHNOLOGIES PART NUMBER, DATE CODE (YYWW) AND DEVICE NOMINAL OPEN TEMPERATURE IN BOTH DEG-F AND DEG-C. APPLY A COLORED DOT NEXT TO THE CODING. REFER TO TABLE.

FOR REFERENCE ONLY, CHECK LATEST REVISION BEFORE USE. PARTS MADE TO THIS PRINT MUST CONFORM TO E9898 REV. E		529 PLEASANT STREET P.O. BOX 2964 ATTLEBORO, MA 02703	
DRAWN PAF DATE 01-AUG-2005 ENGINEER S. MARQUIS DATE 01-AUG-2005 APPROVED R. NABB DATE 01-AUG-2005 APPROVED P. BERG DATE 01-AUG-2005	SENSATA TECHNOLOGIES PROPRIETARY AND CONFIDENTIAL. NEITHER THIS PRINT NOR THE INFORMATION CONTAINED HEREON IS TO BE USED AGAINST THE INTERESTS OF SENSATA TECHNOLOGIES OR AGAINST THE INTERESTS OF ANY OF ITS AFFILIATED COMPANIES OR WHOLLY OWNED SUBSIDIARIES.	TITLE PROBE TYPE THERMISTAT ENVELOPE DRAWING	
DO NOT SCALE DRAWING THIRD ANGLE PROJECTION	DEVICE: 28509 PROJECT: 1063	SIZE C DWG NO. 28509	REV. D SCALE 1:1 AUTOCAD SHEET 1 OF 1