

SECTION A-A
SCALE 8:1

REVISIONS				
ZONE	LTR	DESCRIPTION	DATE	APPROVED

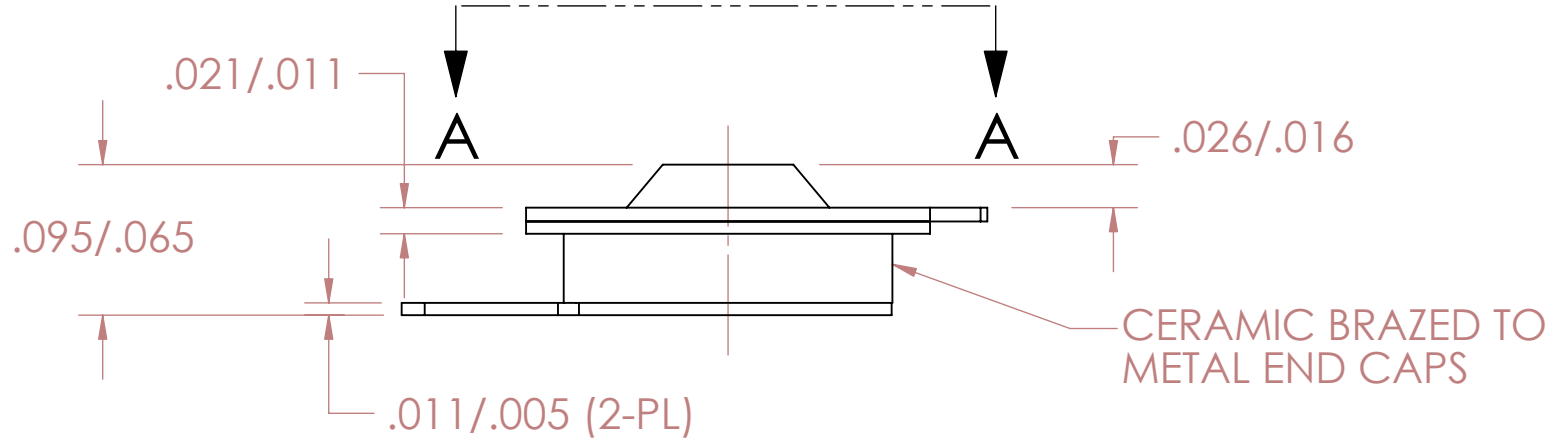
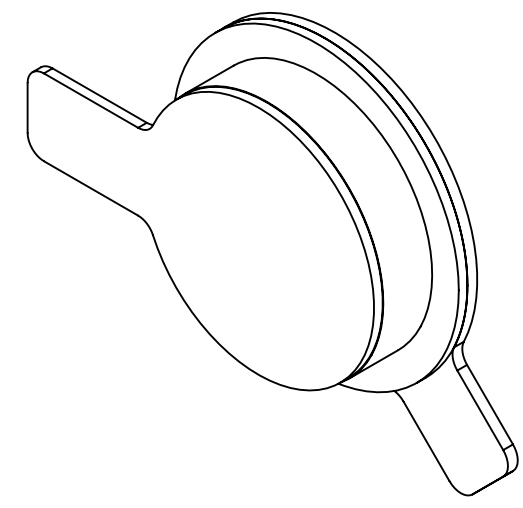
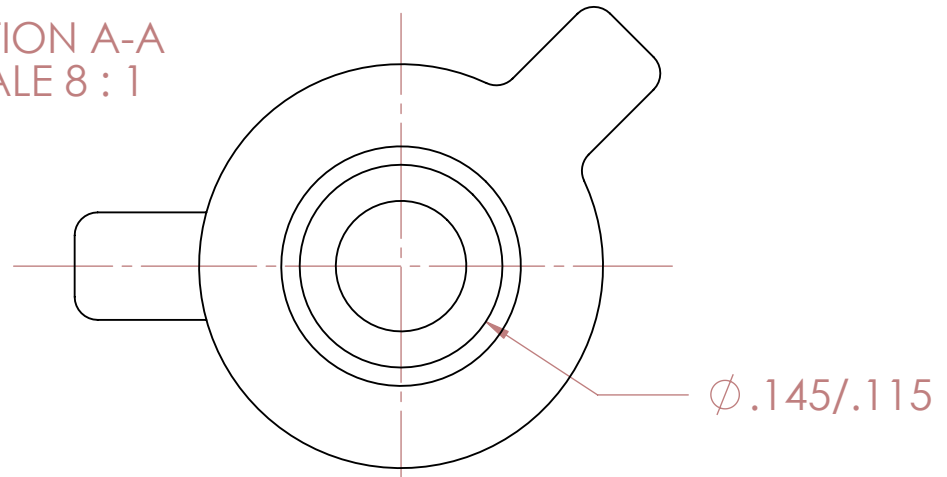

CERAMIC BRAZED TO METAL END CAPS

NOTES:

PART NO. 4BTL12-*-**
PART NO. 4BTF12-*-**

"L" DESIGNATES OPEN ON TEMPERATURE RISE
"F" DESIGNATES CLOSE ON TEMPERATURE RISE

* WHEN CUSTOMER'S TEMPERATURE CHARACTERISTICS ARE ESTABLISHED, A DASH NO. WILL BE ASSIGNED, THEREBY COMPLETING THE PART NO.

** IF WIRE LEADS ARE REQUIRED, A SECOND DASH NO. WILL BE ASSIGNED TO THE COMPLETED PART NO.

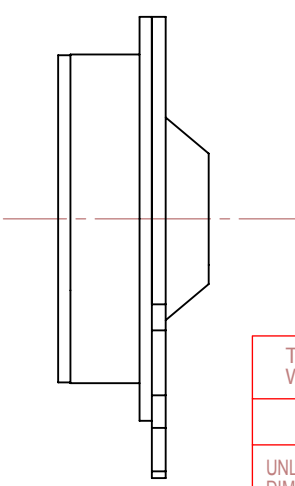
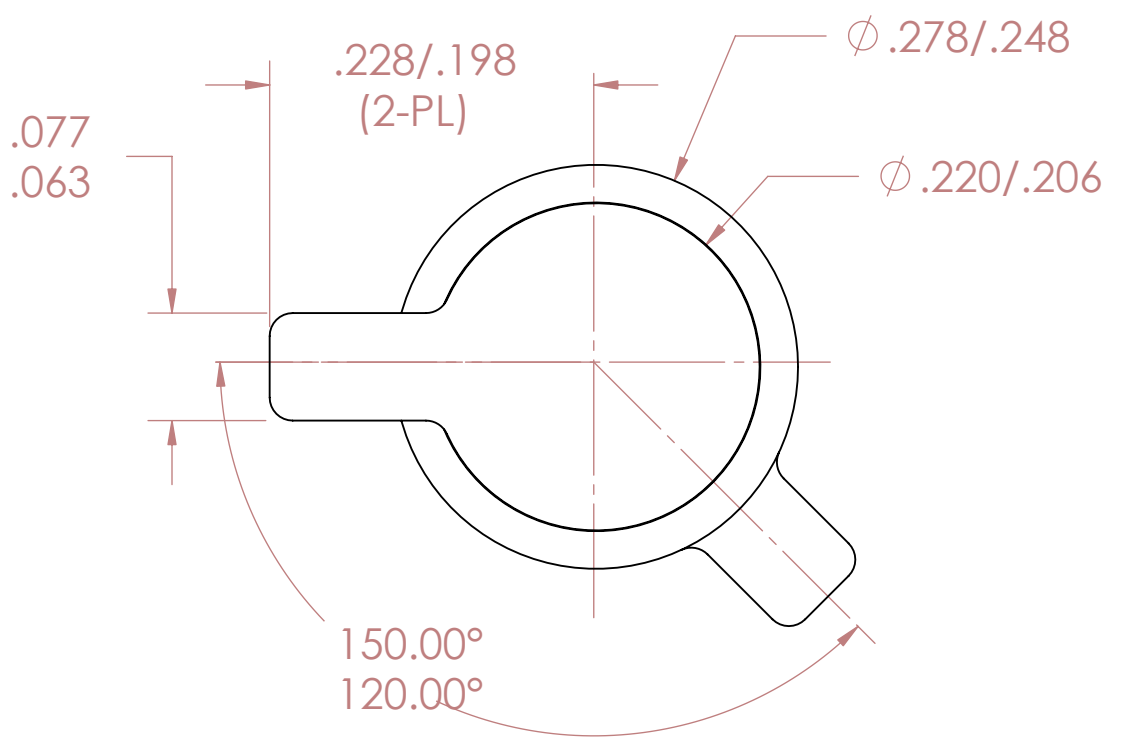

THIS IS A CAD DRAWING. THE GEOMETRY IN THE ASSOCIATED CAD COMPUTER FILE IS DIMENSIONALLY ACCURATE. WHEN DRAWING IS BEING REVISED, THE GEOMETRY MUST BE UPDATED IN ALL VIEWS AND ON ALL SHEETS.

UNLESS OTHERWISE SPECIFIED DIMENSIONS ARE IN INCHES		DRAWN S. MARQUIS	DATE 3/25/02	TEXAS INSTRUMENTS ATTLEBORO, MA. 02703		KLIXON CONTROL PRODUCTS DIVISION	
TOLERANCES ON FRACTIONS DECIMALS ANGLES		ENGINEER		TITLE THERMOSTAT SWITCH ENVELOPE DRAWING			
MATERIAL		APPROVED		SIZE B	CODE IDENT NO. 82647	4BT-12 STYLE	
		APPROVED		SCALE		SHEET	
		SIGNATURES ON FILE. REFER TO ELECTRONIC CHANGE NOTICE.					

NEITHER THIS PRINT NOR THE INFORMATION CONTAINED THEREON IS TO BE USED AGAINST THE INTEREST OF TEXAS INSTRUMENTS, INC. OR AGAINST THE INTERESTS OF ANY OF ITS AFFILIATED COMPANIES OR WHOLLY OWNED SUBSIDIARIES.

FOR REFERENCE ONLY CONSULT TEXAS INSTRUMENTS CUSTOMER SERVICE FOR LATEST REVISION BEFORE USE