

REVISIONS				
ZONE	LTR	DESCRIPTION	DATE	APPROVED

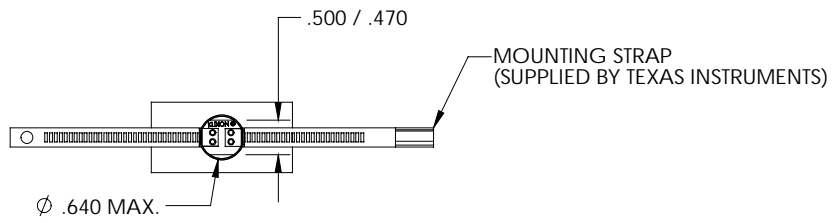

PART NO. 7BT2L15F - * - **
7BT2F15F - * - **

* "L" DESIGNATES OPEN ON TEMPERATURE RISE
"F" DESIGNATES CLOSE ON TEMPERATURE RISE

* WHEN CUSTOMER'S TEMPERATURE CHARACTERISTICS ARE ESTABLISHED, A DASH NO. WILL BE ASSIGNED, THEREBY COMPLETING THE PART NO.

** WHEN A WIRE LEAD IS DESIRED TO BE WELDED ON TO DEVICE, A SECOND DASH NO. WILL BE ASSIGNED.

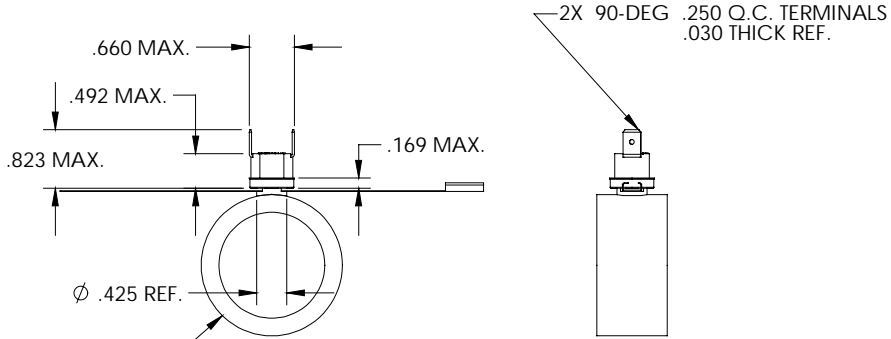

- NOTES:
- 1) PIPE ADAPTER WILL CONFORM TO PIPE DIAMETERS RANGING FROM 0.75 - INCHES TO 6 - INCHES.
 - 2) ORIENTATION OF THERMOSTAT TO MOUNTING STRAP IS NOT CONTROLLED.
 - 3) DEVICE IS TO BE ATTACHED BY CUSTOMER TO PIPE SURFACE VIA TEXAS INSTRUMENTS SUPPLIED STRAP INSERTED THRU SLOT IN ADAPTER BELOW SWITCH.

THIS IS A CAD DRAWING. THE GEOMETRY IN THE ASSOCIATED CAD COMPUTER FILE IS DIMENSIONALLY ACCURATE. WHEN DRAWING IS BEING REVISED, THE GEOMETRY MUST BE UPDATED IN ALL VIEWS AND ON ALL SHEETS.

UNLESS OTHERWISE SPECIFIED DIMENSIONS ARE IN INCHES	DRAWN S. MARQUIS	DATE 3/25/02	TEXAS INSTRUMENTS ATILEBORO MA 02705		
TOLERANCES ON FRACTIONS DECIMALS ANGLES	ENGINEER		TITLE		
MATERIAL	APPROVED		THERMOSTAT SWITCH ENVELOPE DRAWING		
	APPROVED		SIZE B	CODE IDENT NO. 82647	7BT2-15F STYLE
SIGNATURES ON FILE. REFER TO ELECTRONIC CHANGE NOTICE.			SCALE	SHEET	

NEITHER THIS PRINT NOR THE INFORMATION CONTAINED THEREON IS TO BE USED AGAINST THE INTEREST OF TEXAS INSTRUMENTS, INC. OR AGAINST THE INTERESTS OF ANY OF ITS AFFILIATED COMPANIES OR WHOLLY OWNED SUBSIDIARIES.

FOR REFERENCE ONLY CONSULT TEXAS INSTRUMENTS CUSTOMER SERVICE FOR LATEST REVISION BEFORE USE