

4

3

2

1

MAXIMUM VOLTAGE DROP	% RATED CURRENT			MOUNTING NUT	PART NO.	AMP. RATING	CUSTOMER PART NO.
	200	400	600				
0.75	40-120	3-26	1-12	TIN PLATED BRASS	7270-1-3	3	
0.65	40-100	3-22	1-10	MS25082-C21	7270-1-5	5	MS24509-A-5
0.50	10-70	.75-7.0	.25-2.5	MS25082-C21	7270-1-7 1/2	7 1/2	MS24509-A-7 1/2
				MS25082-C21	7270-1-10	10	MS24509-A-10
				MS25082-C21	7270-1-15	15	MS24509-A-15
				TIN PLATED BRASS	7270-1-20	20	
				TIN PLATED BRASS	7270-1-25	25	
				TIN PLATED BRASS	7270-1-30	30	
				TIN PLATED BRASS	7270-1-35	35	
				TIN PLATED BRASS	7270-1-38	38	

REVISIONS						
ZONE	LTR	7270-1	DESCRIPTION	PROJ. 438	DATE	APPROVED
	R		MS24509-A-5 WAS MS24509-A-15.	ECN0021625.DP	3-31-05	R.G.

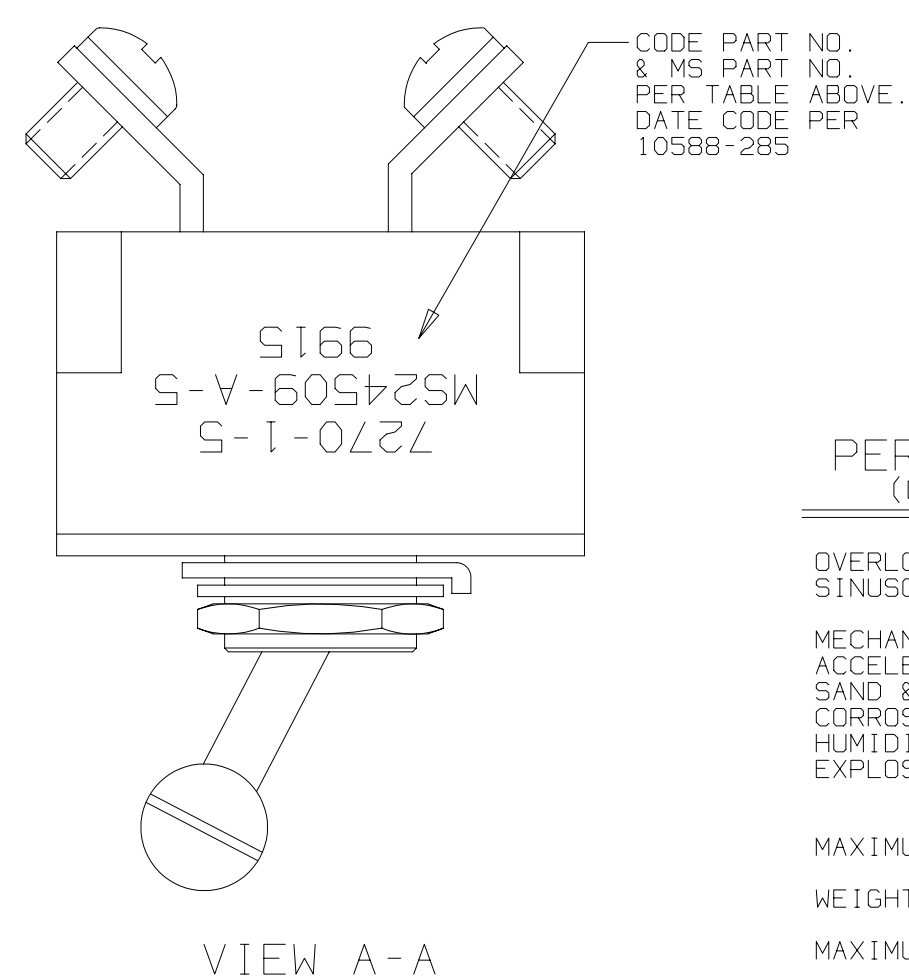
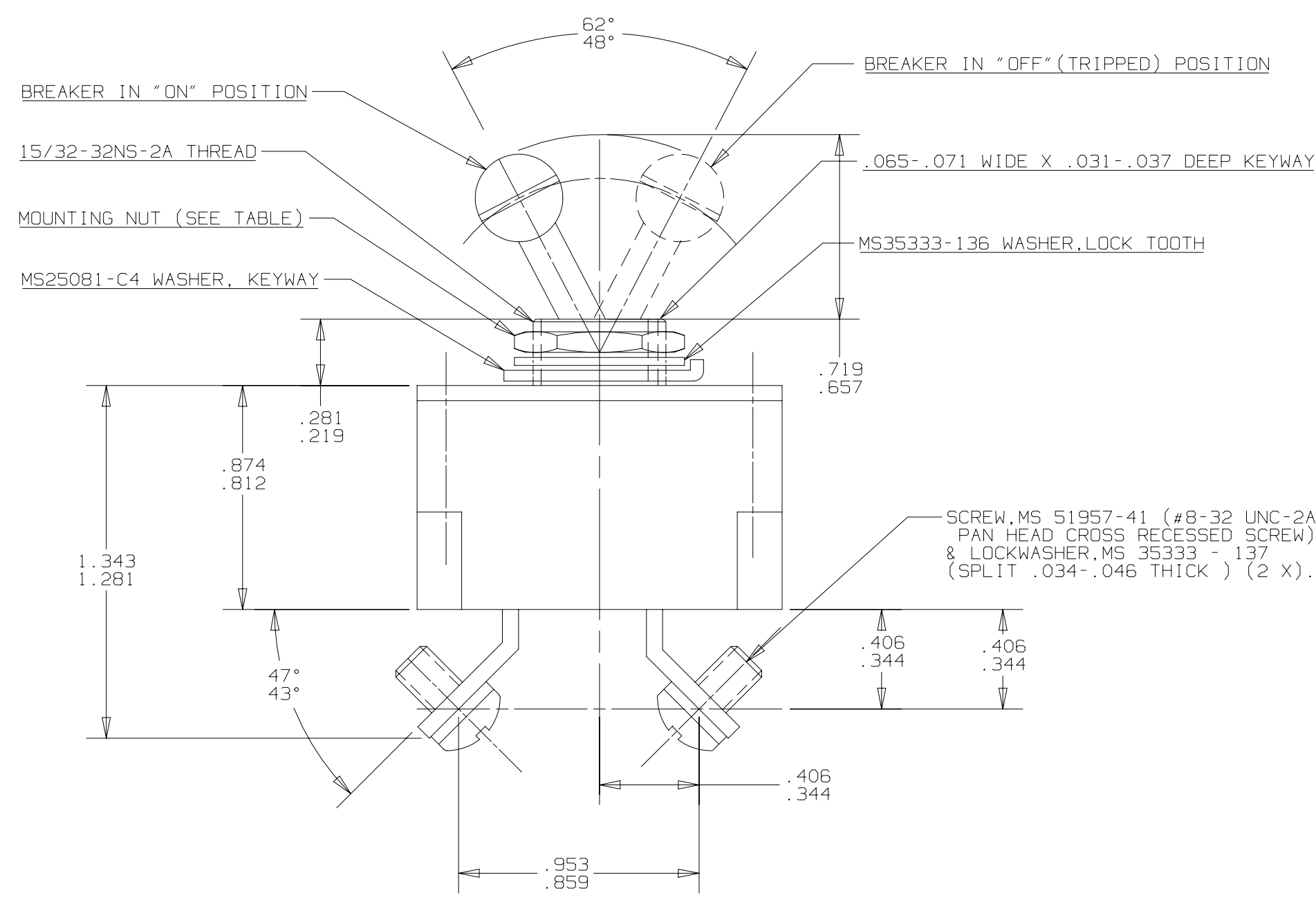
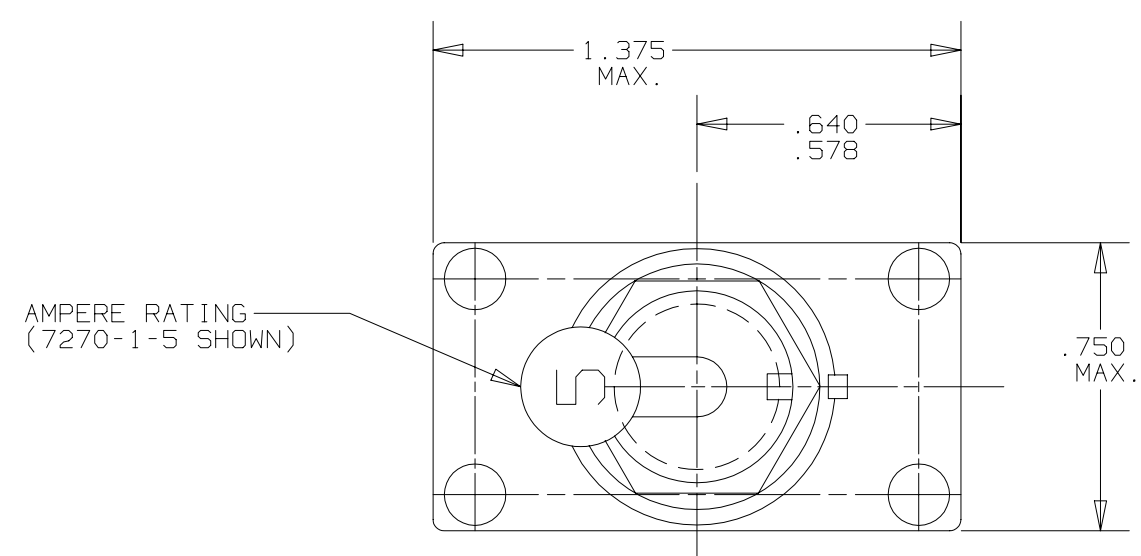

PERFORMANCE CHARACTERISTICS
(DETAIL PERFORMANCE PER MIL-C-5809)

OVERLOAD CYCLING-----100 CYCLES AT 200% RATING
 SINUSOIDAL VIBRATION-----10 G'S 50-500 HZ
 MECHANICAL SHOCK-----30 G'S AT 11.0 MILLISECOND DURATION
 ACCELERATION-----10 G'S MINIMUM
 SAND & DUST-----12 HOURS
 CORROSION -----SALT SPRAY 48 HOURS
 HUMIDITY-----10 DAYS
 EXPLOSION PROOF-----WHILE INTERRUPTING RUPTURE CURRENTS

MAXIMUM OPERATING ALTITUDE: 70,000 FT.
 WEIGHT: 39.0 GRAMS MAX.
 MAXIMUM OPERATING FORCES:
 PULL OUT-----6 LBS. MAX.
 RESET-----6 LBS. MAX.

CURRENT INTERRUPTION CAPACITY: 4,000 A @ 30 VDC.
 3,500 A @ 120 VAC, 400HZ.

ENDURANCE:
 120 VAC-----400 HZ INDUCTIVE -----5000 CYCLES
 120 VAC-----400 HZ RESISTIVE -----5000 CYCLES
 30 VDC-----INDUCTIVE -----200 CYCLES
 30 VDC-----RESISTIVE -----5000 CYCLES
 NO LOAD-----MECHANICAL -----10000 CYCLES

CALIBRATION:

AMBIENT TEMP.	HOLD	TRIP
+25°C	115% RATING	145% RATING
-40°C	138% RATING	175% RATING
+71°C	80% RATING	125% RATING

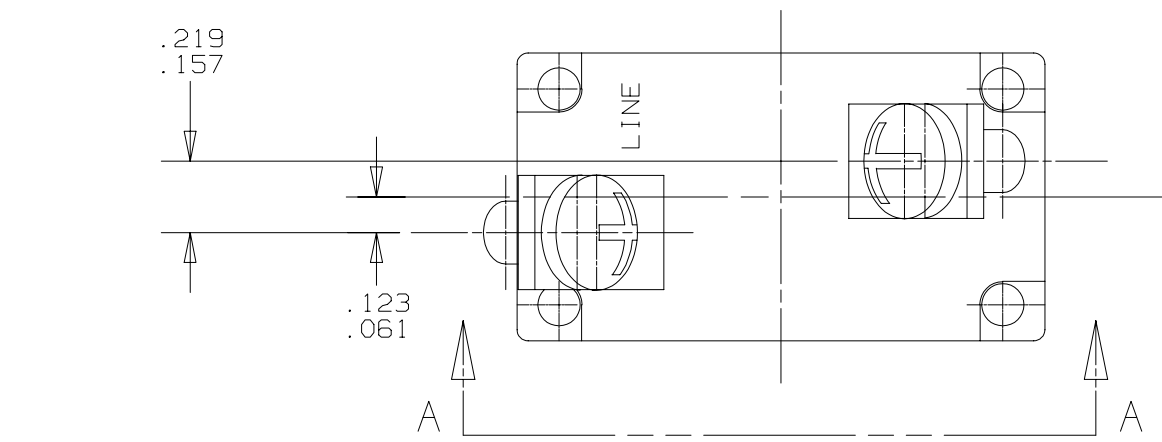

NOTES:
 1. EPOXY SURFACES ARE NON-DIMENSIONED. ENVELOPE DRAWING DIMENSIONS DO NOT APPLY TO THESE PROJECTED EPOXY SURFACES.

UNLESS OTHERWISE SPECIFIED DIMENSIONS ARE IN INCHES		DRAWN O. LARSEN	DATE 5-3-95	TEXAS INSTRUMENTS ATTLEBORO, MASSACHUSETTS 02703 KLAXON CONTROL PRODUCTS DIVISION
TOLERANCE ON FRACTIONS DECIMALS ANGLES		ENGINEER M. J. LAVADO	5-3-95	
		APPROVED H. HIRSBRUNNER	5-16-89	TITLE 7270-1 TYPE TRIP FREE SWITCH TYPE CIRCUIT BREAKER ENVELOPE DRAWING
		APPROVED PETER G. BERG	5-3-95	SIZE CODE IDENT NO. C 82647
MATERIAL		SIGNATURES ON FILE. REFER TO ELECTRONIC CHANGE NOTICE.		7270-1
			SCALE: 2X	SHEET 1 OF 1