



**Product Bulletin**

**KLIXON**

**SP SERIES  
Refrigeration Package**



**Key Features/Benefits**

- Applicable to fractional horsepower compressors used in refrigerators, freezers, water coolers, dehumidifiers, vending machines, and similar refrigeration applications.
- Utilizes ceramic PTC (Positive Temperature Coefficient) pill materials to energize/de-energize motor start windings.
- Readily available for 120 and 220 volt applications.
- Available with 1/8", 1/4" and 3/16" termination.
- Allows direct mounting of the run capacitor in the 5SP model.
- Provides significant installed cost savings opportunities by requiring fewer components to attach to the compressor, particularly the 5SP which features a run capacitor mount for easy assembly.
- Eliminates run capacitor wiring harness in 5SP models.
- Eliminates terminal cover.

**Product Overview**

The Sensata SP Refrigeration Package including the 4SP and 5SP, is a compact motor starter and motor protector package. The SP serves as a combination control which:

1. Uses industry leading 4TM motor protector
2. Performs the PTC solid state starter function
3. Replaces the compressor terminal cover
4. Available for both RSIR and RSCR applications
5. 5SP eliminates the need of wiring harness for a run capacitor

The SP unit plugs directly onto the compressor terminal pins. This provides installed cost savings opportunities through the elimination of the terminal cover and a reduction in assembly labor as well as the elimination of the run capacitor wiring harness in the 5SP model.

**Quality and Performance**

**PTC Reliability**

- High reliability solid state motor starter
- Life cycle: minimum 500,000 cycles at maximum rated current/voltage conditions
- 100% electrically tested twice
- Dissipates less than 2 watts under normal operating conditions

**4TM Reliability**

- Life cycle: designed to achieve a minimum of 10,000 electrical cycles
- Minimum 15 day locked rotor testing

**Agency Certified**

- UL/CUL recognized: File SA3745
- IEC/ENEC Certified: File 2014531.01

**Convenience**

- Fits most existing compressor terminal fences
  - Eliminates retooling
- Elimination of 4TM reapplication in most cases
  - Easy product conversion
- 5SP allows for flexibility in run capacitor size and shape
  - Can accommodate various capacitors
- 4SP and 5SP one piece connector design allows for simultaneous disconnect
- Optional 3/16" continual anti-miswire features or 1/8" one piece simultaneous disconnect termination

## Electrical Component Assembly

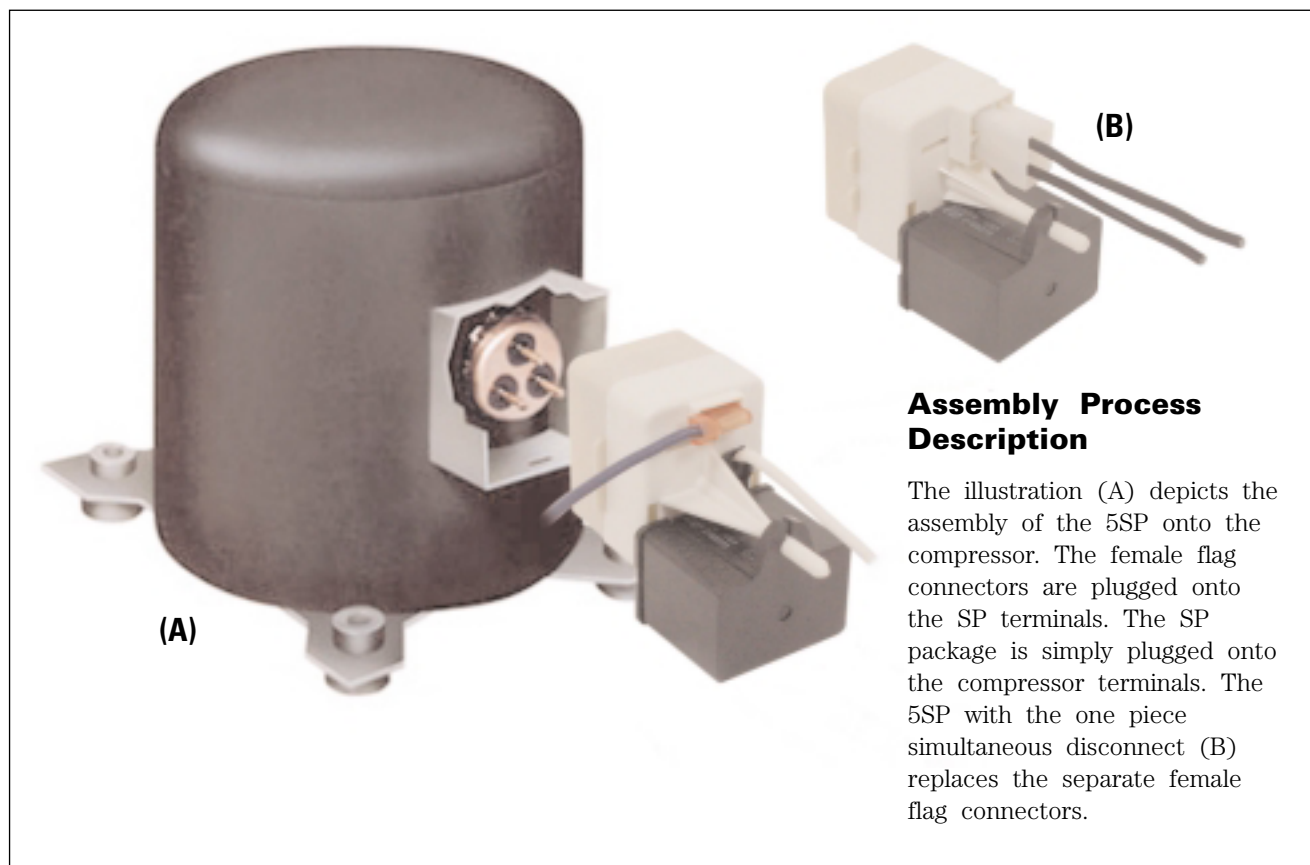

## SP Models

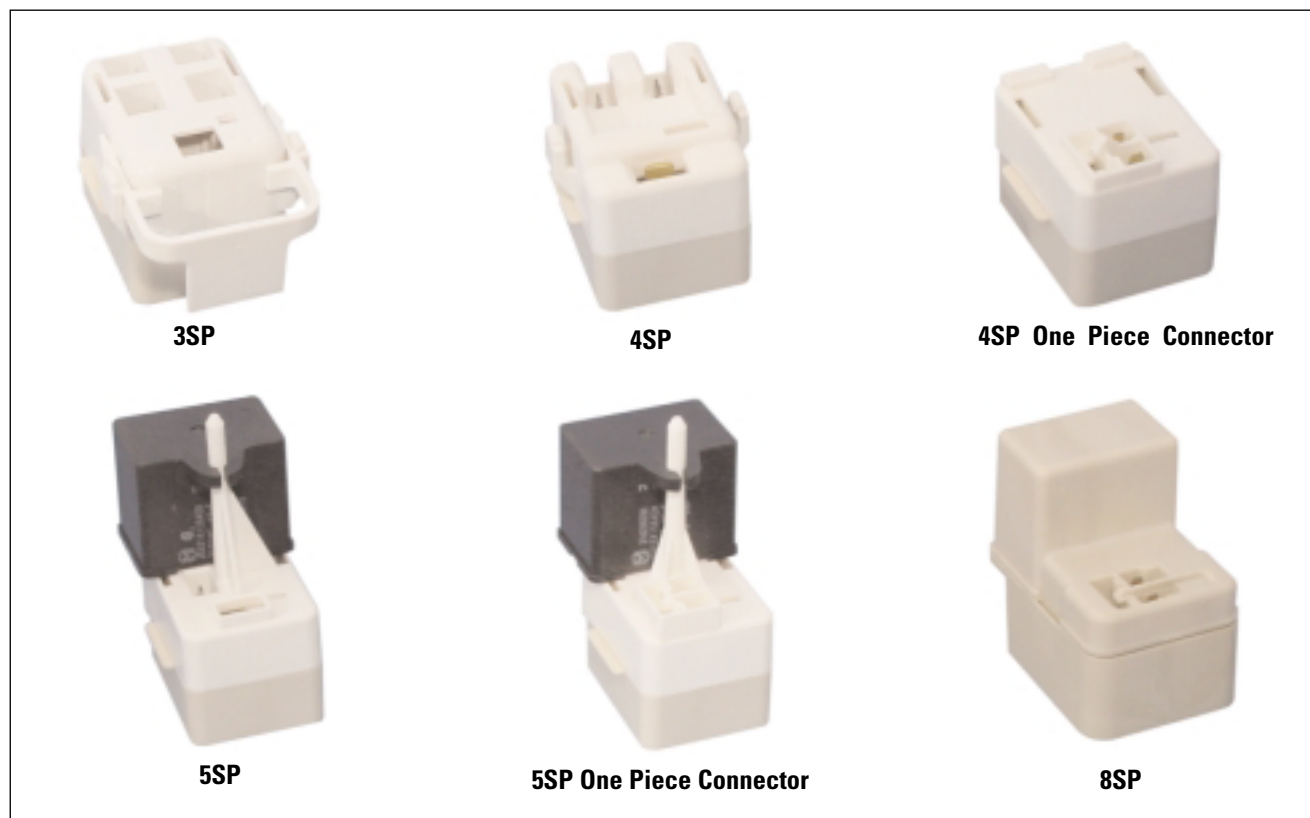

## PTC Performance

When power is first applied to the compressor via the SP, the PTC pill is in the low resistance state. Current flows through the PTC pill to the start windings, causing a beneficial phase angle shift between start and main windings, and resulting in an increase in the starting torque. The current flow through the PTC pill causes self-heating and it switches to the high resistance state, resulting in low power dissipation while the compressor is running.

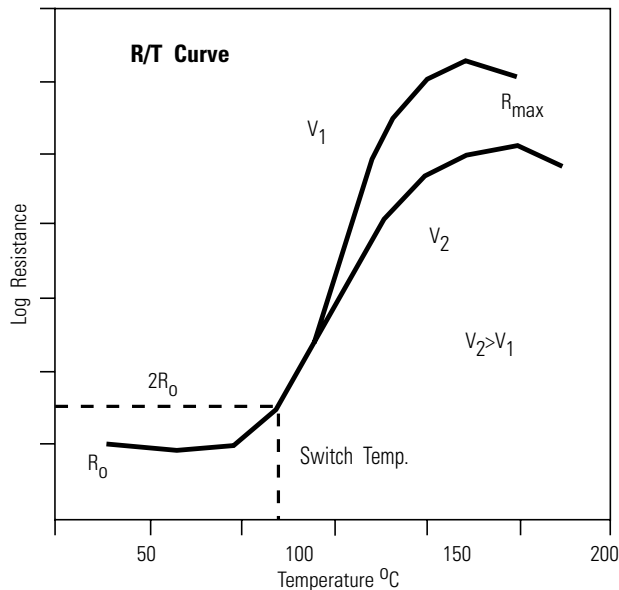

## Electrical Schematics

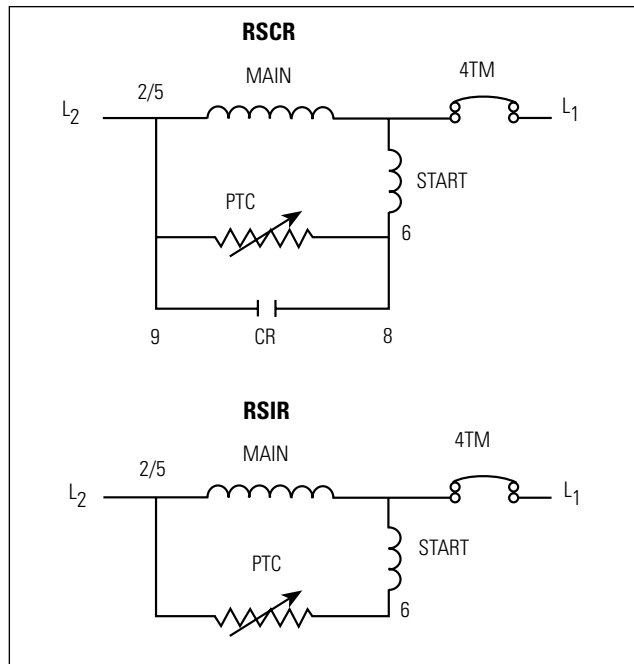

## Combo Coding System

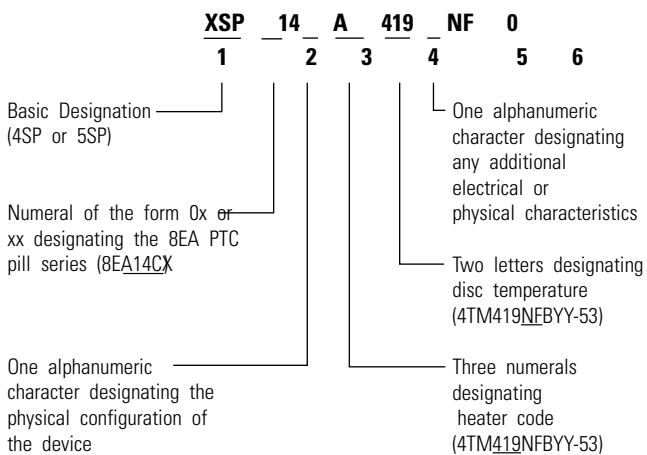

\*For specific physical or electrical characteristics of the device please contact Sensata Technologies directly

## Common PTC Electrical Rating

250 SP Series	Application Voltage	$V_{max} I_{max}$	Nominal Resistance (Ohms)	Heat Capacity mCp
14CX	120	180 / 12	$5.0 \pm 20\%$	1.40
15CX	120	200 / 12	$6.8 \pm 20\%$	1.40
16CX	120	200 / 10	$10 \pm 20\%$	1.40
17CX	240	300 / 7	$22 \pm 20\%$	1.40
18CX	240	355 / 6	$33 \pm 20\%$	1.40
19CX	240	250 / 8	$15 \pm 20\%$	1.40
20CX	240	400 / 5	$4.7 \pm 20\%$	1.40

For other ratings contact Sensata Technologies.

## PTC Motor Starter Application Procedure

### Step 1: Assemble Data Required for New Applications

	<u>Example</u>
R <sub>0</sub> Resistance .....	5.0 Ohms
Max. Volt (V <sub>max</sub> ) .....	162 VAC
Max. Current (In Rush) .....	8 AMP
Switch Time of Motor .....	>0.5 Sec @ 8 AMP Ambient 25°C
Motor Type .....	RSCR
Reset Time .....	<80 Sec @ Nom. Volt Ambient 25°C
Test Requirements .....	• 250K Cycles @ Max. Operational Conditions  • 300 Hrs. @ Max. Volt +10%

**Step 2:** Select PTC pill based on resistance and maximum operating conditions.

(See electrical rating on previous page).

**Step 3:** Select 8EA physical configuration based on motor type. (See terminal configurations on previous page).

### Step 4: Switch Time Calculation

The amount of time required for PTC to switch into its high resistance state can be approximated as follows:

<u>Equation</u>	<u>Example</u>
$\text{Time (Sec)} = \frac{M_{CP} (T_S - T_A)}{I^2 R}$	R = 5 Ohms (R = 5 x .8 = 4)
M <sub>CP</sub> = Heat Capacity (Watt-Sec/°C)	I = 8 Amps
T <sub>S</sub> = Switch Temperature (°C)	T <sub>S</sub> = 120°C
T <sub>A</sub> = Ambient Temperature (°C)	T <sub>A</sub> = 25°C
I = Inrush Current (Amps-Rms)	M <sub>CP</sub> = 1.60
	$\text{Time (Sec)} = \frac{1.60 (95)}{(8^2) (4)}$
R = Initial Device Resistance Under Voltage (Use R <sub>0</sub> x 0.8)	Switch Time = 0.59 Sec.

Theoretical Calculated PTC Switch Time  
Should be ≥ Time Required to Start Motor

### For further information write or call:

#### Sensata Technologies

529 Pleasant Street  
Attleboro, Massachusetts 02703-0964  
Phone: (508) 236-3800  
website: [www.sensata.com](http://www.sensata.com)



## Glossary

R <sub>0</sub>	– Measured resistance value at 25°C±2°C voltage of 2.0 volts.
Cooldown Time	– Time required for the PTC resistance to return to two times the initial value (2R <sub>0</sub> )
Curie Point (Switch Temp.)	– Temperature obtained with a resistance value of two times (2R <sub>0</sub> ) the minimum resistance value (R <sub>0</sub> )
V <sub>max</sub>	– Maximum operating voltage which may be applied across the PTC continuously at the ambient temperature specified and in a steady high resistance state.
V <sub>r</sub>	– Application rated supplied voltage/ 120 or 240 VAC (below V <sub>max</sub> )
I <sub>ss</sub>	– Steady state current remaining at maximum operating voltage.
I <sub>max</sub>	– Maximum operating current.

## Application Notes

- The surface and terminals of the SP device and its components can reach high temperatures under normal running conditions. Any material in contact with the SP device and its terminals, including wire and quick-connect receptacle plastic insulation, should have a minimum temperature rating (RTI) of 105°C. Adequate spacing should be provided to insulate lower-rated materials from this heat source.
- The SP device and its components should be protected from potential sources of liquid, such as the evaporator tray and water connections.
- Certain materials, such as chlorine (Cl) containing gases, can degrade the characteristics of the SP device and its components. The SP device and its components should not be exposed to Sulphur (S) or chlorine (Cl) containing gases, and must be kept away from materials that can generate them. In particular, avoid the use of polyvinyl chloride (PVC) insulation in contact with the SP device and its terminals.

**Important Notice:** Sensata Technologies reserves the right to make changes to, or to discontinue, any product or service identified in this publication without notice. Before placing orders, users should obtain the latest version of the relevant information to verify that the information being relied upon is current.

Sensata Technologies assumes no responsibility for customers' product designs or applications. Users must determine the suitability of the Sensata device described in this publication for their application, including the level of reliability required. Many factors beyond Sensata's control can affect the use and performance of a Sensata product in a particular application, including the conditions under which the product is used and the time and environmental conditions in which the product is expected to perform. As these factors are uniquely within the user's knowledge and control, it is essential that the user evaluate the Sensata product to determine whether it is fit for a particular purpose and suitable for the user's application.

Sensata Technologies products are sold subject to Sensata's Terms and Conditions of Sale which can be found at [www.sensata.com/terms.htm](http://www.sensata.com/terms.htm)